

IoT converter datasheet

Key features

- multiple communication interfaces
 - interface 1: M-Bus, Wireless M-Bus, RS-485, impulse inputs
 - interface 2: LoRaWAN, NB-IoT
- battery or external power supply
- remote configuration enabled
- edge computing enabled thanks to LUA scripting interface
- IP65 outdoor protection



Description

The IoT converter is a device capable of interconnecting different kinds of communication interfaces between each other and passing data through this interconnections.

Communication interfaces supported by IoT converter can be split into two groups. The first group consists of M-Bus, RS485, impulse inputs and Wireless M-Bus interfaces. The second one consists of LoRaWAN and NB-IoT interfaces which are used especially in the Internet of Things (IoT) concept. The IoT converter can be configured in a way to interconnect interfaces between groups mentioned above.

The IoT converter can be powered by different kind of batteries or using an external power supply..

Because of the variability of use cases covered by the IoT converter it is possible to easily configure converter via a PC application connected by a USB cable. For changes that need to be done when the device is in operation,

the IoT converter supports remote configuration via LoRaWAN or NB-IoT interface.

The IoT converter also implements a LUA scripting interface that serves for algorithmic processing of measured data directly on the converter. An example of using a LUA scripting interface can be calculation of the water flow per unit of time and sending the data based on the results of comparison with previously set threshold. In this example the IoT converter would act as a water pipe failure monitor.

The housing has an IP65 protection which allows to use the IoT converter outdoor.

To sum up, the IoT converter allows to interconnect well known and widely spread communication technologies with the emerging ones which are widely used in the Internet of Things concept, such as LoRaWAN or NB-IoT.

Applications

- smart metering (automatic reading of water meters, gas meters, electricity meters, heat and cooling meter)
- industrial processes' monitoring
- energy audits

General specification

Housing

- IP65, suitable for outdoor
- dimensions: 123 x 82 x 56 mm
- operating temperature: from -30 °C to +60 °C

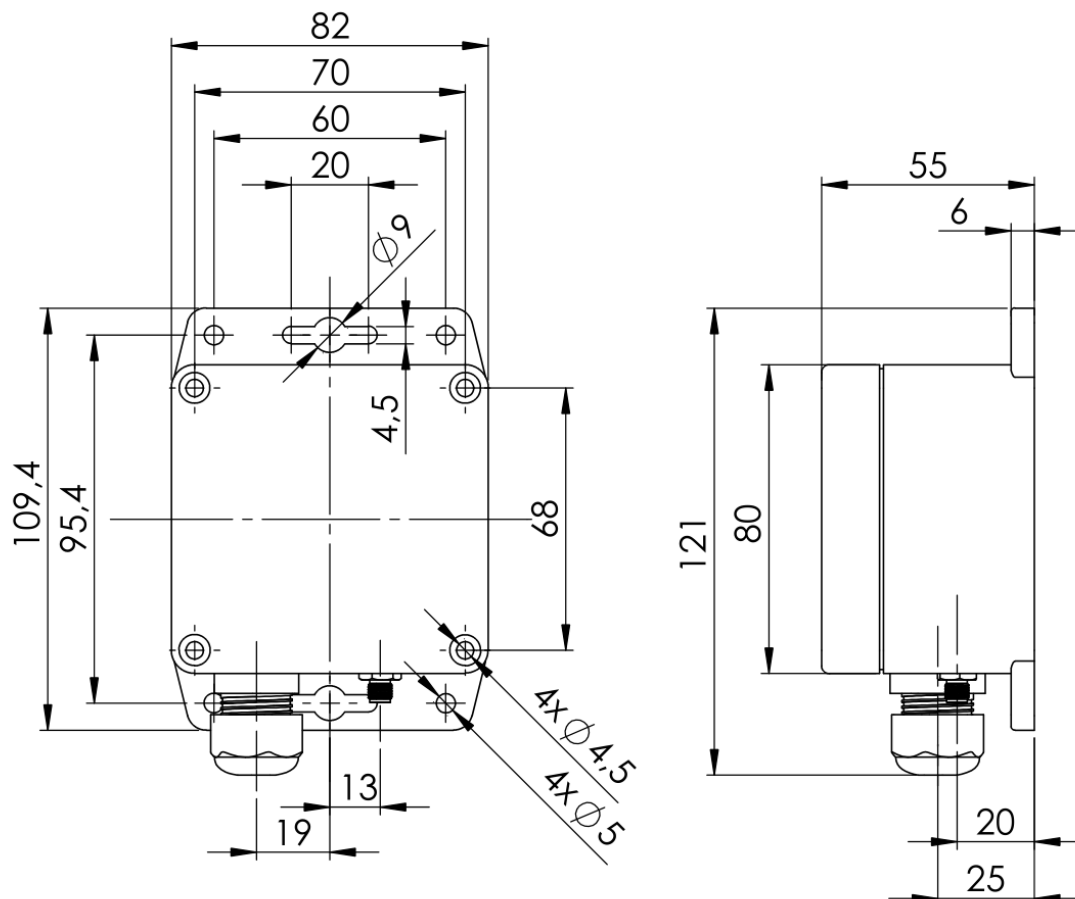

Picture 1: IoT converter dimensions

Power supply

Battery power supply

The battery lifetime depends on many different factors. For example, in case of battery operated IoT convert equipped with LoRaWAN and M-Bus interfaces the main factors are the LoRaWAN spreading factor (SF), the LoRaWAN output power (TXP), the length of data read from the M-Bus device and the length of the data send through the LoRaWAN interface.

The battery variants which can be used as IoT converter power supply are:

- lithium 3,6VDC AA-cell (2 600 mAh) - connected using the battery holder
- lithium 3,6VDC C-cell (7 700mAh) - connected using the connector
- lithium 3,6VDC D-cell (17 000mAh) - connected using the connector

External power supply

It is possible to power device from external power supply which is connected to the device through terminal block located inside the IoT converter.

- supply voltage: 85-305 VAC
- frequency: 47-63 Hz
- maximum input power: 4W

Status indication

Device operating status is indicated using three internal LEDs.

- 2x blue - successful device initialization
- 1x green - data successfully send
- 1x red - failed to send data

Control and configuration

Inside the IoT converter, there is a button that enables the user to immediately wake up the IoT converter (asynchronously to the converter's internal clock).

The IoT converter can be configured via the PC application or remotely via the LoRaWAN or NB-IoT network.

LUA scripting interface

Beyond the configuration options accessible via PC application the LUA scripting interface is implemented inside the IoT converter. The LUA scripting interface enables users to implement its own logic inside the IoT converter. Detailed information about LUA scripting interface can be found in separate document.

Interfaces specification (group 1)

M-Bus interface

- technology: M-Bus (EN13757-3)
- device type: master
- communication speed: 300 - 9600 Bd
- connection of up to 5UL (unit loads) supported

RS485 interface

- technology: RS485 bus (EIA-485)
- device type: master
- communication speed: 1200 - 115200 Bd (higher baudrates on demand)
- connection of up to 128UL (unit loads) supported
- Modbus RTU, Modbus ASCII and Profibus DP protocols supported

Impulse interface

- impulse counter: 32bit (up to $2^{32} = 4\,294\,967\,296$ pulses)
- minimum pulse length: 30 ms

Wireless M-Bus interface

- technology: Wireless M-Bus (EN13757-4)
- device type: master
- supported modes: T1

Interfaces specification (group 2)

LoRaWAN

- technology: LoRaWAN
- device class: A
- frequency : 868 MHz (ISM band)
- antenna: external via SMA connector (gain according to type of antenna used)

NB-IoT

- technology: NB-IoT
- frequency: 900 MHz (licensed band)
- antenna: external via SMA connector (gain according to type of antenna used)

Product variants

All variants of IoT converter can be found in the table below.

| | ACR | -CONV- | | - | | - | |
|----------------------------------------------|-----|--------|----|---|---|---|---|
| Interface (group 1) | | | | | | | |
| M-Bus | | | M | | | | |
| RS485 | | | R | | | | |
| Impulse counter with 2 channels | | | I2 | | | | |
| Impulse coutner with 4 channels | | | I4 | | | | |
| Wireless M-Bus | | | W | | | | |
| Interface (group 2) | | | | | | | |
| LoRaWAN | | | | | L | | |
| Narrowband IoT (NB-IoT) | | | | | N | | |
| Power supply | | | | | | | |
| Battery - Lithium 3,6VDC AA-cell (2 600 mAh) | | | | | | | A |
| Battery - Lithium 3,6VDC C-cell (7 700 mAh) | | | | | | | C |
| Battery - Lithium 3,6VDC D-cell (17 000 mAh) | | | | | | | D |
| External - Supply voltage 85-305 VAC | | | | | | | E |

Table 2: Product variants

Accessories

- Battery - Lithium 3,6VDC AA-cell (2 600 mAh)
- Battery - Lithium 3,6VDC C-cell (7 700 mAh)
- Battery - Lithium 3,6VDC D-cell (17 000 mAh)
- Configuration cable - USB to UART
- Antenna - 868MHz, 3dBi